

Description

As the world's smallest FM receiver, the Si4708/09 extends Silicon Laboratories Si4700 FM tuner family and further increases the ease and attractiveness of adding FM radio reception to mobile devices. Requiring only 6.25 mm² of board space, the Si4708/09 is the world's smallest size along with a minimum component count, flexible and proven programmability, and superior, proven performance. The Si4708/09 leverage Silicon Laboratories' highly successful and patented Si4700/01/02/03 FM tuner, and are software compatible to existing Si4700/01/02/03 FM tuner designs. The Si4708/09 benefits from proven digital integration and 100% CMOS process technology, resulting in a completely integrated solution. The Si4708/09's proven and highly flexible functionality caters to the subjective nature of audio preferences and variable FM broadcast environments worldwide.

The Si4709 incorporates a digital processor for the European Radio Data System (RDS) and the US Radio Broadcast Data System (RBDS) including all required symbol decoding, block synchronization, error detection, and error correction functions. RDS enables data such as station identification and song name to be displayed to the user. The Si4709 offers a detailed RDS view and a standard view, allowing adopters to selectively choose granularity of RDS status, data, and block errors. Si4709 software is backwards compatible to the proven Si4701/03, adopted by leading cell-phone, PND, and MP3 manufacturers world-wide.

The Si4708/09 device's high level of integration and complete FM system increases quality to manufacturers, improves device yields and simplifies device manufacturing and final testing.

Features

- Worldwide FM band support (76–108 MHz)
- 2.5 x2.5 mm 16-pin QFN package
 - Pb-free/RoHS compliant
- Digital low-IF receiver
- Frequency synthesizer with integrated VCO
- Seek tuning
- Automatic frequency control (AFC)
- Automatic gain control (AGC)
- Excellent overload immunity
- Signal strength measurement
- Programmable de-emphasis (50/75 μs)
- Adaptive noise suppression
- Volume control
- Line-level analog output
- 32.768 kHz reference clock
- RDS/RBDS processor (Si4709 only)
- 2-wire and 3-wire control interface
- -1.8 to 5.5 V supply voltage
- 2.7 to 5.5 V_A supply voltage
- Integrated LDO regulator allows direct connection to battery

Applications

- Cellular handsets
- MP3 players
- PDAs, Notebook PCs
- Portable radios
- Portable navigation
- Automobile applications
- Consumer electronics
- USB FM radios

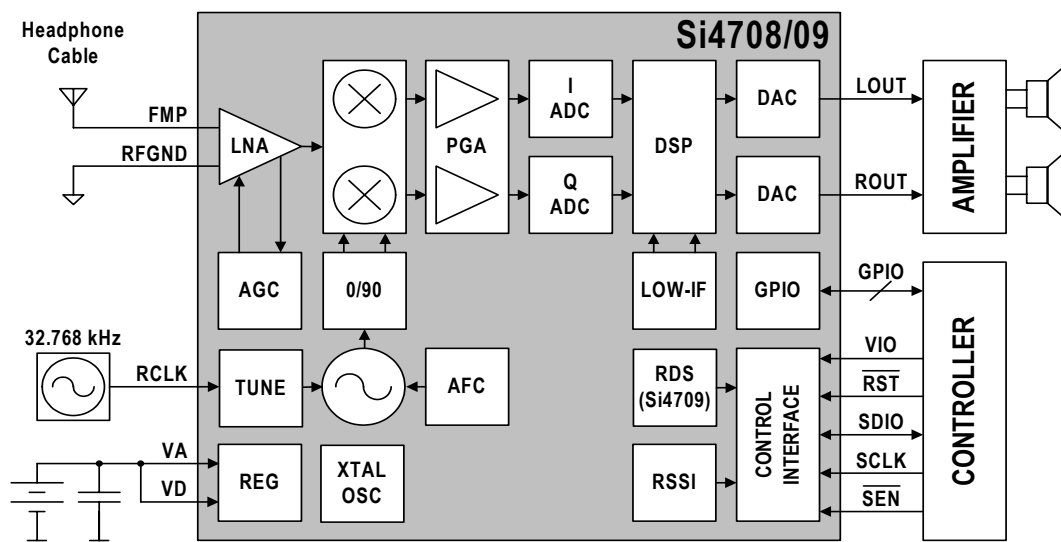

Selected Electrical Specifications

Parameter	Symbol	Test Condition	Min	Typ	Max	Unit
Input Frequency	f_{RF}		76	—	108	MHz
Sensitivity		(S+N)/N = 26 dB	—	1.1	—	$\mu\text{V EMF}$
Input IP3		$ f_2 - f_1 > 1 \text{ MHz}; f_0 = 2 \times f_1 - f_2$ AGC disabled	—	106	—	$\text{dB}\mu\text{V EMF}$
Adjacent Channel Selectivity		$\pm 200 \text{ kHz}$	—	50	—	dB
Alternate Channel Selectivity		$\pm 400 \text{ kHz}$	—	70	—	dB
RCLK Frequency			—	32.768	—	kHz
RCLK Frequency Tolerance			-200	—	200	ppm
Audio Output Voltage			72	80	90	mVrms
Audio Band Limits		$\pm 1.5 \text{ dB}$	30	—	15k	Hz
Audio S/N			—	59	—	dB
Audio THD			—	0.1	0.5	%
Supply Voltage	V_D, V_A		2.7	—	5.5	V
Interface Supply Voltage	V_{IO}		1.5	—	3.6	V
Ambient Temperature	T_A		-20	25	85	$^\circ\text{C}$
Supply Current	I_{AD}		—	14.6	—	mA
Powerdown Current	I_{PD}		—	8.5	12	μA
Seek/Tune Time			—	—	60	ms/channel
SCLK Frequency	f_{CLK}	3-wire operation	—	—	2.5	MHz
	f_{SCL}	2-wire operation	—	—	400	kHz
Powerup Time		From powerdown	—	—	110	ms

Pin Assignments

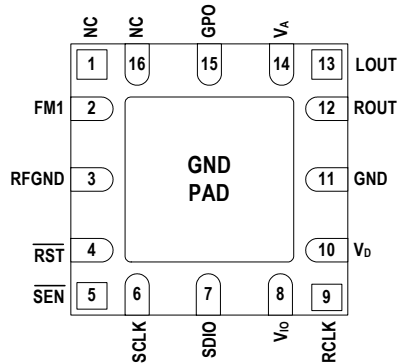

Package Information

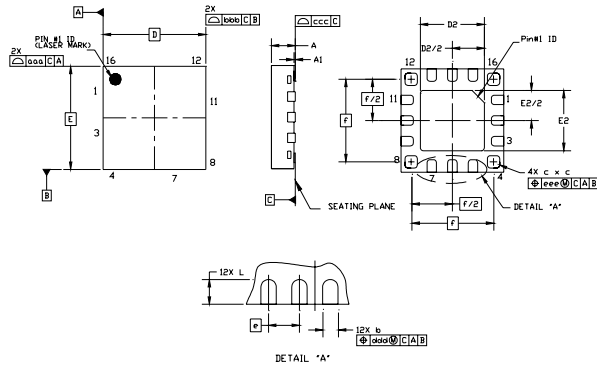

Symbol	Millimeters		
	Min	Nom	Max
A	0.50	0.55	0.60
A1	0.00	0.02	0.05
b	0.18	0.23	0.28
c	0.25	0.30	0.35
D	2.50 BSC		
D2	1.35	1.40	1.45
e	0.50 BSC		
E	2.50 BSC		

Symbol	Millimeters		
	Min	Nom	Max
E2	1.35	1.40	1.45
f	2.00 BSC		
L	0.25	0.30	0.35
aaa	—	—	0.05
bbb	—	—	0.05
ccc	—	—	0.08
ddd	—	—	0.10
eee	—	—	0.10